



EASY WAY OF DRUG PICKING

Shyamala.S.C, Lavanya R, Sangeetha B.S, Chethan B.R
Asst. Professor, Dept of ECE,
PESITM, Shivamogga, Karnataka, India

Abstract: Medical shops are playing a vital role in human health care system now a day. When the medical shop is more crowded, customers struggle to purchase medicines. This creates a significant problem for the supplier in terms of delivering medicines to customers on time and during an emergency. The suggested method employs an autonomous robot that picks up the medicine from a storage area and puts it in the dispenser box without the need for human intervention. It solves the problems of the existing system, which is operated manually.

Keywords: Raspberry Pi, GSM, Thermal Printer, L293D, Camera, IR Sensor, Servo motor, DC Motor.

I. INTRODUCTION

Robotics is one of the most important fields in the world of industrial applications in everyday life. Robotics may have an impact on a variety of domains in the technological manipulations, and this may be intelligent with advancements in areas such as sensors and storage. Early robots were operated using infrared technology, robotics became more integrated into the domains of services, security and safety. They may be widely used in distributed computer systems, surveillance cameras, and this robotic intelligence system has been used in pick and place, merging subsystems, and this system can be used in dangerous areas to complete tasks where human may be harmed. In recent decades, due to the improper food habits of the people and also due to the various environmental pollutions, the chances of getting affected to a disease by them are more.

As a result, the number of patients visiting hospitals on a daily basis has increased. In addition, hospitals and medical shops play a vital role in human health care by providing the proper medicines and medication at the right time. The aged person or the persons having eye problem who are working in the warehouse can't be able to differentiate the medicine properly. So there may be a medication error.

When the warehouse is crowded, the customers have to wait for long time to buy the required quantity of medicines and delivering medicines to customers takes much too long. As a result, the customers have to wait for a long time to buy the medicines. To overcome this problem, our proposed model takes less time to locate the medicine in the storage area and quickly sends it to the customers. This makes our medical shops smarter, more reliable and more friendly to customers.

II. LITERATURE SURVEY

- 1) Published by IEEE (Sep-2019), Design and implementation of an intravenous medication dispensing robot.. In this paper a small-sized intravenous medication dispensing robot suitable for ampoule and vial is designed and implemented based on the analysis of hospital manual dispensing process
- 2) International Research Journal of Engineering and Technology (IRJET)[Mar-2019], Drug Dispensing Robot in Medical Shops In this paper A proximity sensor is a sensor able to detect the presence of nearby objects without any physical contact. A gripper is a device which enables the holding of an object to be manipulated.
- 3) International Journal of Current Engineering and Scientific Research (IJCESR) [2019], Automated Medical Dispensing System Using Robotics, In this paper In the LED display it displays the medicine and its quantity. The micro controller ARDUINO MEGA 2560 is used to interface components such as RTC, Ultrasonic sensor, IR sensor, L293D motor driver, fingerprint sensor and GSM module, and also is used to enter and store data about the patient using a keypad present in robot.
- 4) International Journal of Recent Technology and Engineering (IJRTE) [2019], IoT based Automated Medicine Dispenser for Online Health Community using Cloud, in this paper the process of prescribing and governing a patient's medication involves several steps including Ordering, Dispensing, Transcribing and administration. Dispensing: the pharmacist must check for delivery of medicines in the correct dose considering the chemical matching. The proposed solution composed of three main components: Medicine dispenser, data store and user interface.

III. OBJECTIVES

- 1) The main objective of the system is to develop a system that can recognize the name of a drug and its position in the warehouse.
- 2) To design a system that can choose the quantities of the drug from the pillbox as specified by the Merchandise Associate.
- 3) To develop a system that could also calculate and print an invoice for customers after the medicine is packed.

IV. HARDWARE DESCRIPTION

- 1) Raspberry Pi 3 Model B+: The Raspberry Pi 3 Model B+ is the latest product in the Raspberry Pi 3 range, boasting a 64-bit quad core processor running at 1.4GHz, dual-band 2.4GHz and 5GHz wireless LAN, Bluetooth 4.2/BLE, faster Ethernet,

and PoE capability via a separate PoE HAT The dual-band wireless LAN comes with modular compliance certification, allowing the board to be designed into end products with significantly reduced wireless LAN compliance testing, improving both cost and time to market.

- 2) IR sensor: used to detect the exact position of the pill box
- 3) GSM: GSM stands for Global System for Mobile Communication. GSM is an open and digital cellular technology used for mobile communication. It uses 4 different frequency bands of 850 MHz, 900 MHz, 1800 MHz and 1900 MHz. It uses the combination of FDMA and TDMA.
- 4) Thermal Printer: A thermal printer is a printer that makes use of heat in order to produce the image on paper. Due to quality of print, speed, and technological advances it has become increasingly popular and is mostly used in airline, banking, entertainment, retail, grocery, and healthcare industries. Thermal printing does not make use of ink or toner unlike many other printing forms but largely depends on thermal papers for producing the images. They are also quiet popular in creating labels owing to speed of printing.
- 5) Web Camera: A webcam is a video camera that feeds or streams an image or video in real time to or through a computer network, such as the Internet. Webcams are typically small cameras that sit on a desk, attach to a user's monitor, or are built into the hardware.

V. SOFTWARE DESCRIPTION

1) Raspberry Pi OS: Raspberry Pi OS (formerly Raspbian) is a Debian-based operating system for Raspberry Pi. Since 2013, it has been officially provided by the Raspberry Pi Foundation as the primary operating system for the Raspberry Pi family of compact single-board computers. English, and other languages.

- 2) Python and other programming language: The code on which the system operates is mainly Python.
- 3) VNC viewer: VNC stands for Virtual Network Computing. VNC Viewer gathers your input (mouse, keyboard, or touch) and sends it for VNC Server to inject and actually achieve remote control. You need a VNC Server for the remote computer you want to control, and a VNC Viewer for the computer or mobile device you want to control from.
- 4) Advanced IP scanner: Advanced IP Scanner is a free network scanner that can locate and analyze all computers available on your wireless or wired local network. With its help, you can get remote access to all PCs, such that you can copy and share files present on the shared folders and turn off systems remotely. The application is portable and can be used by network admins anytime, anywhere.

VI. METHODOLOGY

The above figure shows the block diagram of the system. In medical shops initially the medicine boxes are scanned by a barcode scanner that are present in a medical warehouse and information such as medicine name, manufacturer name, manufacturing date and expiry date are recorded into a Raspberry pi database. The drugs are manually organized alphabetically in the storage space after entering their details in the Raspberry pi server. Numbering system are also used to keep medicines in medicine box, which are kept in the storage area. When a customer order medicine, the robot searches the medicine name in its server. It depicts the location of that medicine in the storage area. The robot will go to a particular place and pick the medicine and then generates the invoice. Then deliver to the customers.

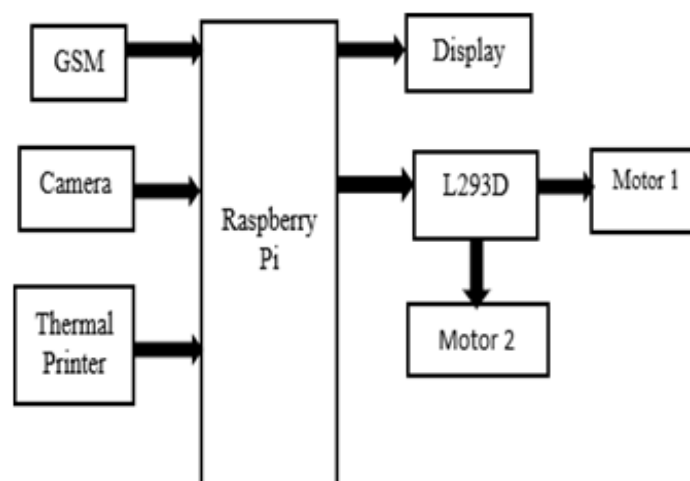

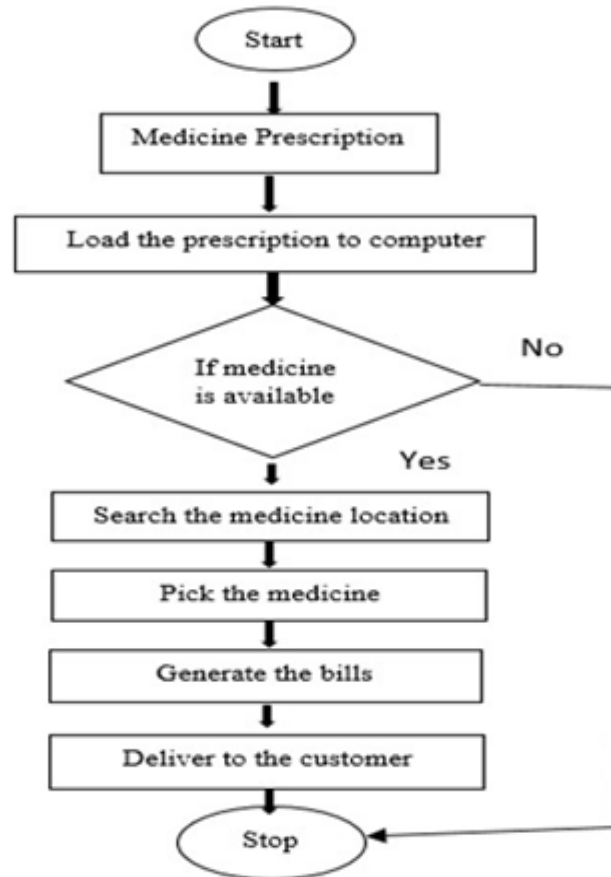

Fig 2: Flow chart of the system

The above figure shows the flow chart of the system. When a medical prescription is issued. The medicine prescription will be uploaded to the pc. It performs a server-based search for the drug. If the medicine was available, it obtains the location

of the drug and travels to that place to grab the medicine. Then entire bill for the medicine will be generated and delivered to the customers. The process will terminate if the drug is unavailable.

VII. EXPERIMENTAL RESULTS



Fig.3: Prototype Model



Fig. 4: Commands through mobile

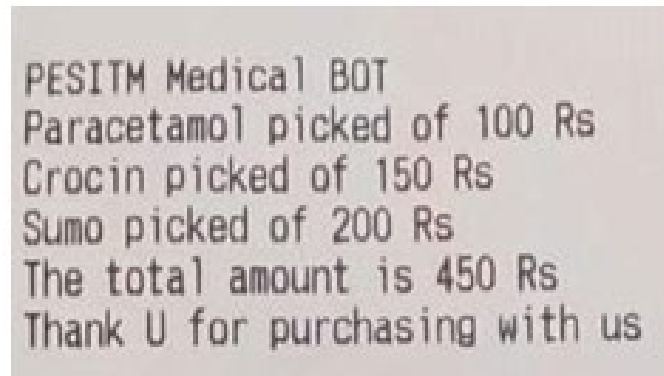

Fig. 5: Bill

The proposed system was successfully tested to demonstrate its effectiveness and feasibility. The figure 4.1 shows the prototype model of our project, figure 4.3 and 4.4 shows mobile commands for activating the robot to pick the medicine. If the medicine is not present, we will get a message back from the robot saying that the medicines are not available please contact other medical shops. Figure 4.5 shows the bill which is printed along with total cost of the medicines

VIII. CONCLUSION

The proposed system can used to deliver the medicine to the pharmacy and medical supply warehouse. When the needs of the patients communicated by the doctors can be met directly by the robot, it will cut down on unnecessary waiting time for patients as well as for other patients. Additionally, this will decrease the existing crowd at the medical stores. To eliminate manual labour a second robot can be used to retrieve the medication from the dispenser box. Once it has been delivered and place it the appropriate cell. Any type of medical store, whether retail or wholesale, can use the suggested system it is a practical way to deal with the shortage of competent labours and ensure constant efficiency.

IX. REFERENCES

- [1]. Robot Yucheng He, Ying Hu, Xueqi Fu, Xiaoli Cheng*, Haiyang Jin* and Peng Zhang. Design and Implementation of An Intravenous Medication IEEE International Conference on Cyborg and Bionic Systems (CBS) Munich, Germany, September 19-20.
- [2]. M. Sathiya priya 1, R. Anitha 2, M. Surendiran 3, K. Meyvel 4, L. Manivannan5. DRUG PICKING ROBOT IN MEDICAL SHOPS. International Research Journal of Engineering and Technology

- (IRJET).
- [3]. Manjunatha Y R N Lohith, Bhavana R, Bindushree S V. MEDIC-The Smart Medicine Dispenser International Journal of Recent Technology and Engineering (IJRTE) ISSN: 2277-3878, Volume-8, Issue-1C, May 2019.
- [4]. H. Hongfang, "Hazard of Insoluble Particles of Clinical Transfusion and Its Prophylaxis," CHINESE NURSING RESEARCH, pp. 812-813, 2003.
- [5]. P. Yulin and D. Ying, "Discussion on occupational exposure protection of medical staff," Today nurse, pp. 22-23, 2007.
- [6]. Conrad C, Fields W, McNamara T, (2010), "Medication room madness: calming the chaos - Journal of Nursing 25(2): 137-44".
- [7]. Suganya G, Premalatha M, Anushka Sharma, Muktak Pandya, IoT based Automated Medicine Dispenser for Online Health Community using Cloud, International Journal of Recent Technology and Engineering (IJRTE) February 2019, IoT based Automated Medicine Dispenser for Online Health Community using Cloud